

REV.	ECN NO.	MODIFY MATTER	DATE	APPROVED
A		RELEASE TO PRODUCTION		

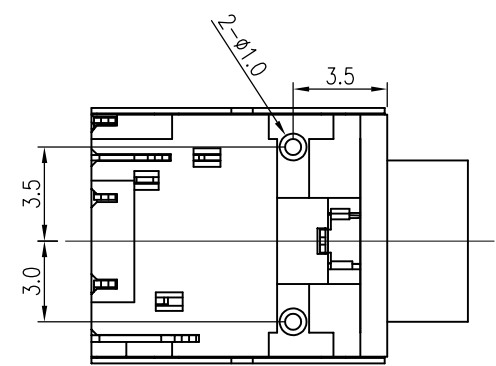

**SPECIFICATION**

1. Rating : DC 30V 0.5A;
2. Contact resistance:  $\leq 0.03 \Omega$ ;
3. Insulation resistance:  $\geq 100M \Omega$  (DC250V);
4. Withstand voltage: 500VAC ;
5. Insertion and extraction force: 3-30N;
6. life test: 5,000 cycles.

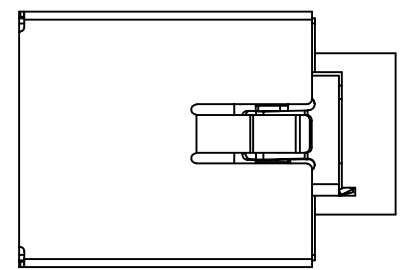
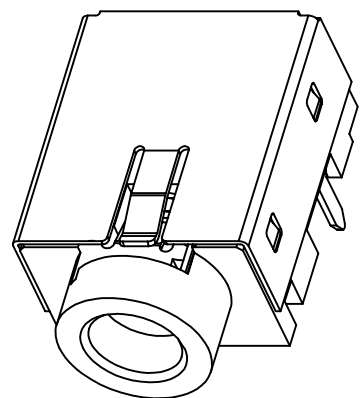
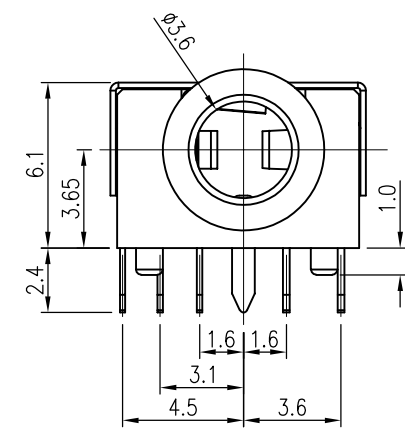
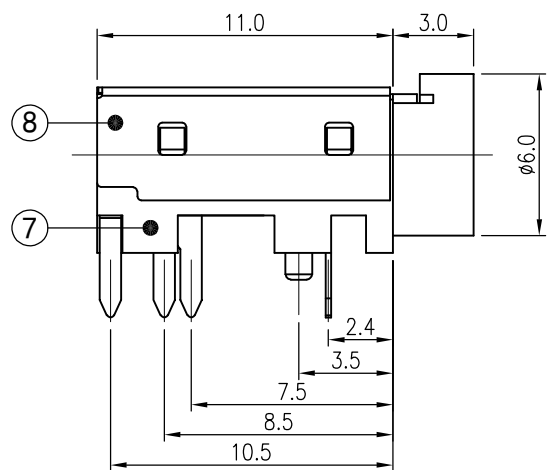
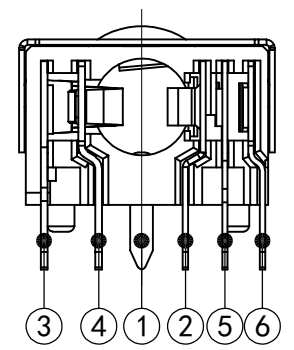

**EAST-2324P-08DX-PPA**

- B:BLACK
- P:PINK(#199C)
- G:GREEN(#577C)

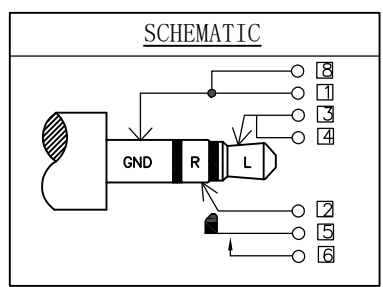
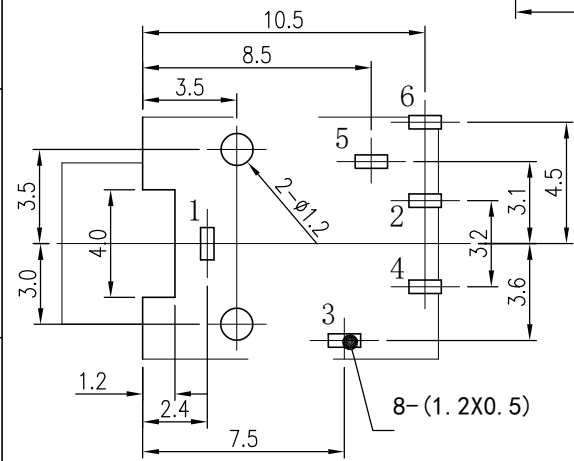

NO.	DESCRIPTION	QTY	MATERIAL	PLATING
8	SHELL	1	SUS	
7	HOUSING	1	PA9T+30%GF, UL94 V-0	
6	CONTACT FOOT	1	PHOSPHOR BRONZE	Matte Sn-Plating
5	SPRING PIECE	1	PHOSPHOR BRONZE	Matte Sn-Plating
4	CURVE PIECE	1	PHOSPHOR BRONZE	Matte Sn-Plating
3	SPRING PIECE	1	PHOSPHOR BRONZE	Matte Sn-Plating
2	SPRING PIECE	1	PHOSPHOR BRONZE	Matte Sn-Plating
1	CONTACT FOOT	1	PHOSPHOR BRONZE	Matte Sn-Plating

TOLERANCES UNLESS OTHERWISE SPECIFIED: X. — X.X ± 0.38 X.XX ± 0.25 X.XXX ± 0.10 Angle ± 1°		CUSTOMER COPY		<b>深圳市东方御业科技有限公司</b> WWW.DFYCONN.COM TEL:0755-27155560	
DRAWN: CHENLEI		2017/09/10		TITIAL: 3.5mm AUDIO JACK	
CHECKED: CHENLEI		2017/09/10		PART NO: EAST-2324P-08DX-PPA (RoHS)	
APPROVED: QINKAI XING		2017/09/10		UNIT: mm	
THESE DRAWING AND SPECIFICATION ARE THE PROPERTY OF Shenzhen Dongfangyue ELECTRONIC CO., LTD., SHALL NOT BE REPRODUCED.		SCALE: N/A		SHEET: 1:1	

**P. C. B LAYOUT TOP VIEW**